

LLTP32-B - 32-UNIT CART WITH TIMER

Product Specifications:

Item Number	LLTP32-B
Material	Powder Coated Steel
Color Finish	Black
Capacity	32 units
Cart Dimensions	28.5"W x 21"D x 38.25"H (w/handle) 28.5"W x 21"D x 38.25"H (w/out handle)
Weight	107 lbs.
Shelf Quantity	3
Shelf Dimensions	Top 2 Shelves: 28"W x 16"D x 11.5"H Bottom Shelf: 28"W x 16"D x 4"H
Divider Make	Rubber Coated Steel
Divider Distance	1.5"
Doors	2 front; 2 back
Ventilation	All sides
Power	Two 16-outlet vertical power strips; UL Approved
Voltage	110V
Cable Management	Charging Cord Clips
Lock	Key-lock on front door and back door; Includes 2 keys
Casters (4)	4" rubber non-skid; two casters include locking brakes
Timer	ETL listed
Ship Method	Freight
Shipping Carton Dims	1 Carton; 31"W x 23"D x 36"H
Shipping Weight	111 lbs.
Assembly Required	Minimal; attach handle bar and casters
Cord Length	10'

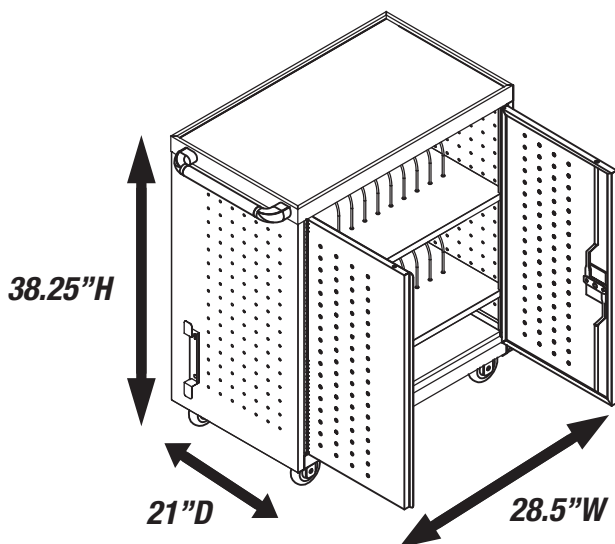

To Order, Call Your
Sales Representative
or 800-323-4656