

Specifications

SMART Board® interactive whiteboard**Model SBM680E**

Overview

Your SMART Board® M680E interactive whiteboard features a durable interactive surface, two damage-resistant pens and SMART's proprietary DVIT® (Digital Vision Touch) technology. The SBM680E model supports dual touch, dual write and intuitive gestures, such as toss, rotate and zoom, available with multitouch operating systems.

The SBM680 interactive whiteboard supports the following Epson® projectors:

- PowerLite 530 for SMART (V11H745520)
- PowerLite 580 for SMART (V11H746520)

See smarttech.com for more information on this product.

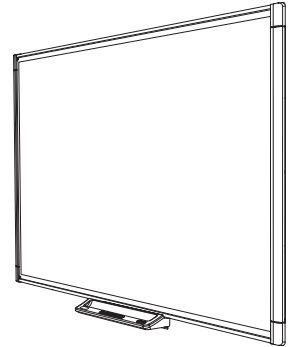
Dimensions and weights¹

Dimensions

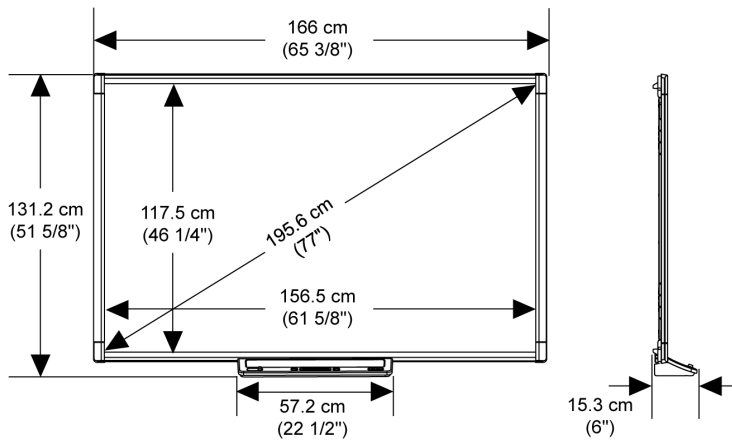
**SMART Board M680E interactive whiteboard****Weight**

40 lb. 13 oz. (18.5 kg)

Shipping dimensions

71 1/4" W × 53" H × 4 1/2" D
(181 cm × 134.6 cm × 11.4 cm)

Shipping weight

52 lb. (23.6 kg)

Accessory box**Shipping dimensions**

33" W × 4" H × 7" D
(83.8 cm × 10.2 cm × 17.8 cm)

Shipping weight

5 lb. 3 oz. (2.4 kg)

¹All dimensions ± 1/8" (0.3 cm). All weights ± 2 lb. (0.9 kg).

Standard features

Software	You can install SMART Product Drivers and SMART Notebook® collaborative learning software from the included DVD or from smarttech.com/downloads . Software upgrades are also available.
Computer requirements	A computer or laptop with a Windows® operating system or Mac operating system software and SMART Notebook software installed. For a complete list of computer requirements, go to smarttech.com/downloads and browse to the latest SMART Notebook software release notes applicable to your computer's operating system. ²
Touch and gestures	You can write, erase and perform mouse functions by touching the interactive whiteboard with your finger or a pen. This interactive whiteboard also features gesture capability, providing a natural and flexible way to interact with content.
Multitouch capabilities	Support for two simultaneous touches enables up to two users to interact with the interactive whiteboard by using the included pens or other objects, or by using their fingers to write and to perform gestures.
SMART Ink™	Smooths out the appearance of the digital ink, improving the legibility of your handwriting. The ink becomes an object you can move and manipulate.
Pen tray	The pen tray connects to the interactive whiteboard and a projector. Use the color select buttons to change digital ink colors. Power and volume controls are available on the pen tray, as are the on-screen keyboard, right-click and orient features.
Pen	Includes two pens
Screen surface	The hard-coated steel surface is durable, is optimized for projection and is compatible with dry-erase markers.
Digitizing technology	Four-camera DVIT
Frame finish	White and light gray (approximates PANTONE® Cool Gray 4C)
Power requirements	6' (1.8 m) power cable and 6" (15 cm) Y-cable. Power consumption is less than 7 W (100V to 240V AC, 50/60 Hz, 5V DC 2.0A).
Computer connection	Includes a 16' (5 m) USB 2.0 cable to connect to the room computer. Your SMART Board M680E interactive whiteboard supports one computer connection on a primary display only.

Temperature specifications

Storage	-4°F to 122°F (-20°C to 50°C)
Operation	41°F to 95°F (5°C to 35°C) with up to 80% humidity, non-condensing

Certification and compliance

Regulatory certification	CSA (U.S./Canada)
---------------------------------	-------------------

²A digital projector isn't included with this model of SMART Board interactive whiteboard. To take advantage of all interactive features, you must integrate a supported Epson digital projector.

Environmental compliance

China	EIP
European Union	REACH, RoHS, WEEE, Packaging and ErP Standby
U.S.	Packaging and Conflict Minerals

Warranty

Interactive whiteboard The interactive whiteboard has a two-year limited equipment warranty or a five-year limited equipment warranty upon registration. See warranty documents for details.

Accessories The accessories have a one-year warranty.

Purchasing information **NOTE**

A digital projector isn't included with this model of SMART Board interactive whiteboard. To take advantage of all interactive features, integrate a digital projector. The SMART Board M680E interactive whiteboard supports the following digital projectors, available from Epson:

- PowerLite 530 for SMART (V11H75520)
- PowerLite 580 for SMART (V11H76520)

Order numbers

SBM680E	77" (195.6 cm) diagonal SMART Board M680E interactive whiteboard with an active pen tray. Includes a SMART Notebook software installation DVD.
---------	--

Optional accessories See smarttech.com/accessories

smarttech.com/support
smarttech.com/contactsupport

© 2016 SMART Technologies ULC. All rights reserved. SMART Board, smarttech, the SMART logo and all SMART taglines are trademarks or registered trademarks of SMART Technologies ULC in the U.S. and/or other countries. All third-party product and company names may be trademarks of their respective owners. This product and/or use thereof is covered by one or more of the following U.S. patents: www.smarttech.com/patents. Contents are subject to change without notice. 03/2016.