

ViewSonic®



SD-Z225

Zero Client Monitor

User Guide

IMPORTANT: Please read this User Guide to obtain important information on installing and using your product in a safe manner, as well as registering your product for future service. Warranty information contained in this User Guide will describe your limited coverage from ViewSonic Corporation, which is also found on our web site at <http://www.viewsonic.com> in English, or in specific languages using the Regional selection box in the upper right corner of our website. "Antes de operar su equipo lea cuidadosamente las instrucciones en este manual"

Model No. VS15177

Compliance Information

NOTE: This section addresses all connected requirements and statements regarding regulations. Confirmed corresponding applications shall refer to nameplate labels and relevant markings on unit.

FCC Compliance Statement

This device complies with part 15 of FCC Rules. Operation is subject to the following two conditions: (1) this device may not cause harmful interference, and (2) this device must accept any interference received, including interference that may cause undesired operation.

This equipment has been tested and found to comply with the limits for a Class B digital device, pursuant to part 15 of the FCC Rules. These limits are designed to provide reasonable protection against harmful interference in a residential installation. This equipment generates, uses, and can radiate radio frequency energy, and if not installed and used in accordance with the instructions, may cause harmful interference to radio communications. However, there is no guarantee that interference will not occur in a particular installation. If this equipment does cause harmful interference to radio or television reception, which can be determined by turning the equipment off and on, the user is encouraged to try to correct the interference by one or more of the following measures:

- Reorient or relocate the receiving antenna.
- Increase the separation between the equipment and receiver.
- Connect the equipment into an outlet on a circuit different from that to which the receiver is connected.
- Consult the dealer or an experienced radio/TV technician for help.

Warning: You are cautioned that changes or modifications not expressly approved by the party responsible for compliance could void your authority to operate the equipment.

Industry Canada Statement

CAN ICES-3(B)/NMB-3(B)

CE Conformity for European Countries

 The device complies with the EMC Directive 2004/108/EC and Low Voltage Directive 2006/95/EC.

Following information is only for EU-member states:

The mark shown to the right is in compliance with the Waste Electrical and Electronic Equipment Directive 2002/96/EC (WEEE). The mark indicates the requirement NOT to dispose the equipment as unsorted municipal waste, but use the return and collection systems according to local law.



Declaration of RoHS2 Compliance

This product has been designed and manufactured in compliance with Directive 2011/65/EU of the European Parliament and the Council on restriction of the use of certain hazardous substances in electrical and electronic equipment (RoHS2 Directive) and is deemed to comply with the maximum concentration values issued by the European Technical Adaptation Committee (TAC) as shown below:

| Substance | Proposed Maximum Concentration | Actual Concentration |
|---|--------------------------------|----------------------|
| Lead (Pb) | 0.1% | < 0.1% |
| Mercury (Hg) | 0.1% | < 0.1% |
| Cadmium (Cd) | 0.01% | < 0.01% |
| Hexavalent Chromium (Cr ⁶⁺) | 0.1% | < 0.1% |
| Polybrominated biphenyls (PBB) | 0.1% | < 0.1% |
| Polybrominated diphenyl ethers (PBDE) | 0.1% | < 0.1% |

Certain components of products as stated above are exempted under the Annex III of the RoHS2 Directives as noted below:

Examples of exempted components are:

1. Mercury in cold cathode fluorescent lamps and external electrode fluorescent lamps (CCFL and EEFL) for special purposes not exceeding (per lamp):
 - (1) Short length (≤ 500 mm): maximum 3.5 mg per lamp.
 - (2) Medium length (> 500 mm and $\leq 1,500$ mm): maximum 5 mg per lamp.
 - (3) Long length ($> 1,500$ mm): maximum 13 mg per lamp.
2. Lead in glass of cathode ray tubes.
3. Lead in glass of fluorescent tubes not exceeding 0.2% by weight.
4. Lead as an alloying element in aluminium containing up to 0.4% lead by weight.
5. Copper alloy containing up to 4% lead by weight.
6. Lead in high melting temperature type solders (i.e. lead-based alloys containing 85% by weight or more lead).
7. Electrical and electronic components containing lead in a glass or ceramic other than dielectric ceramic in capacitors, e.g. piezoelectronic devices, or in a glass or ceramic matrix compound.

Cautions and Warnings

1. Read these instructions completely before using the equipment.
2. Keep these instructions in a safe place.
3. Heed all warnings and follow all instructions.
4. Sit at least 18" / 45cm from the Zero Client Monitor.
5. Always handle the Zero Client Monitor with care when moving it.
6. Never remove the rear cover. This Zero Client Monitor contains high-voltage parts. You may be seriously injured if you touch them.
7. Do not use this equipment near water. Warning: To reduce the risk of fire or electric shock, do not expose this apparatus to rain or moisture.
8. Avoid exposing the Zero Client Monitor to direct sunlight or another heat source. Orient the Zero Client Monitor away from direct sunlight to reduce glare.
9. Clean with a soft, dry cloth. If further cleaning is required, see "Cleaning the Display" in this guide for further instructions.
10. Avoid touching the screen. Skin oils are difficult to remove.
11. Do not rub or apply pressure to the LCD panel, as it may permanently damage the screen.
12. Do not block any ventilation openings. Install the equipment in accordance with the manufacturer's instructions.
13. Do not install near any heat sources such as radiators, heat registers, stoves, or other devices (including amplifiers) that produce heat.
14. Place the Zero Client Monitor in a well ventilated area. Do not place anything on the Zero Client Monitor that prevents heat dissipation.
15. Do not place heavy objects on the Zero Client Monitor, video cable, or power cord.
16. If smoke, an abnormal noise, or a strange odor is present, immediately switch the Zero Client Monitor off and call your dealer or ViewSonic. It is dangerous to continue using the Zero Client Monitor.
17. Do not attempt to circumvent the safety provisions of the polarized or grounding-type plug. A polarized plug has two blades with one wider than the other. A grounding type plug has two blades and a third grounding prong. The wide blade and the third prong are provided for your safety. If the plug does not fit into your outlet, consult an electrician for replacement of the outlet.
18. Protect the power cord from being tread upon or pinched, particularly at the plug, and the point where it emerges from the equipment. Be sure that the power outlet is located near the equipment so that it is easily accessible.
19. Only use attachments/accessories specified by the manufacturer.

(Continued on next page)

20. Use only with the cart, stand, tripod, bracket, or table specified by the manufacturer, or sold with the equipment. When a cart is used, use caution when moving the cart/equipment combination to avoid injury from tipping over.



21. Unplug this equipment when it will be unused for long periods of time.

22. Refer all servicing to qualified service personnel. Service is required when the unit has been damaged in any way, such as: if the power-supply cord or plug is damaged, if liquid is spilled onto or objects fall into the unit, if the unit is exposed to rain or moisture, or if the unit does not operate normally or has been dropped.

Contents

Compliance Information

| | |
|---|-----|
| FCC Compliance Statement..... | i |
| Industry Canada Statement..... | i |
| CE Conformity for European Countries..... | i |
| Declaration of RoHS2 Compliance..... | ii |
| Cautions and Warnings..... | iii |

Copyright Information

| | |
|---------------------------|---|
| Product Registration..... | 2 |
| For Your Records..... | 2 |

Getting Started

| | |
|--|---|
| Package Contents..... | 3 |
| Quick Installation..... | 4 |
| Additional Software Installation (Optional)..... | 4 |
| Wall Mounting (Optional)..... | 5 |

Using the Zero Client Monitor

| | |
|----------------------------------|----|
| Setting the Timing Mode..... | 8 |
| OSD and Power Lock Settings..... | 8 |
| Adjusting the Screen Image..... | 9 |
| Main Menu Controls..... | 10 |
| Main Menu Explanation..... | 10 |

Other Information

| | |
|---------------------------------------|----|
| Specifications..... | 12 |
| Cleaning the Zero Client Monitor..... | 14 |
| Troubleshooting..... | 15 |
| Customer Support..... | 16 |
| Limited Warranty..... | 17 |

Copyright Information

Copyright © ViewSonic® Corporation, 2014. All rights reserved.

Macintosh and Power Macintosh are registered trademarks of Apple Inc.

Microsoft, Windows, and the Windows logo are registered trademarks of Microsoft Corporation in the United States and other countries.

ViewSonic, the three birds logo, OnView, ViewMatch, and ViewMeter are registered trademarks of ViewSonic Corporation.

VESA is a registered trademark of the Video Electronics Standards Association.

DPMS, DisplayPort, and DDC are trademarks of VESA.

Disclaimer: ViewSonic Corporation shall not be liable for technical or editorial errors or omissions contained herein; nor for incidental or consequential damages resulting from furnishing this material, or the performance or use of this product.

In the interest of continuing product improvement, ViewSonic Corporation reserves the right to change product specifications without notice. Information in this document may change without notice.

No part of this document may be copied, reproduced, or transmitted by any means, for any purpose without prior written permission from ViewSonic Corporation.

Product Registration

To fulfill possible future product needs, and to receive additional product information as it becomes available, please visit your region section on ViewSonic's website to register your product online.

For Your Records

| | |
|-------------------------|--|
| Product Name: | SD-Z225 ViewSonic Zero Client Monitor |
| Model Number: | VS15177 |
| Document Number: | SD-Z225_UG_ENG Rev. 1B 12-26-13 |
| Serial Number: | _____ |
| Purchase Date: | _____ |

Product disposal at end of product life

ViewSonic respects the environment and is committed to working and living green.

Thank you for being part of Smarter, Greener Computing.

Please visit ViewSonic website to learn more.

USA & Canada: <http://www.viewsonic.com/company/green/recycle-program/>

Europe: <http://www.viewsoniceurope.com/uk/support/recycling-information/>

Taiwan: <http://recycle.epa.gov.tw/recycle/index2.aspx>

Getting Started

Important! Save the original box and all packing material for future shipping needs.

NOTE: The word “Windows” in this user guide refers to Microsoft Windows operating system.

Package Contents

Your Zero Client Monitor package includes:

- Zero Client Monitor
- Power cord
- D-Sub cable
- Power adapter
- Compliance Information Brochure
- Quick Start Guide
- ViewSonic CD
 - User Guide
 - INF/ICM files*
 - Registration information
 - Additional software (Optional)

NOTE: The INF file ensures compatibility with Windows operating systems, and the ICM file (Image Color Matching) ensures accurate on-screen colors. ViewSonic recommends that you install both the INF and ICM files.

Quick Installation

1. Connect video cable

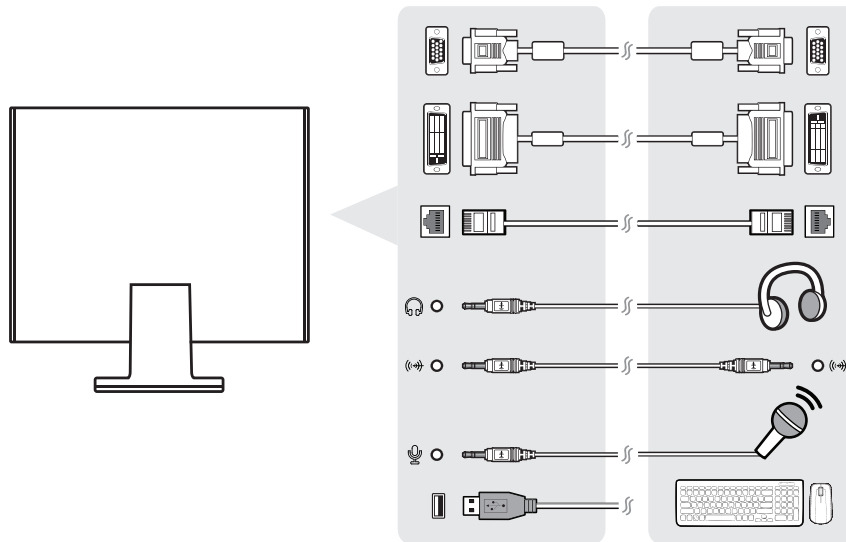

2. Connect power cord (and AC/DC adapter if required)

3. Turn ON Zero Client Monitor

Additional Software Installation (Optional)

1. Load the ViewSonic CD on your CD/DVD drive.
2. Double click on the "Software" folder and choose an application, if desired.
3. Double click on the Setup.exe file and follow the onscreen instructions to complete the simple installation.

Wall Mounting (Optional)

NOTE: For use only with UL Listed Wall Mount Bracket.

To obtain a wall-mounting kit or height adjustment base, contact ViewSonic® or your local dealer. Refer to the instructions that come with the base mounting kit. To convert your Zero Client Monitor from a desk-mounted to a wall-mounted display, do the following:

1. Verify that the power button is turned Off, then disconnect the power cord.
2. Lay the Zero Client Monitor face down on a towel or blanket.
3. Remove the base. (Screws removal might be required.)
4. Find and identify one of the following VESA mount interfaces (a,b,c) located on the back of your display (refer to “Specifications” page for your displays mounting interface). Attach the mounting bracket from the VESA compatible wall mounting kit using screws of the appropriate length.

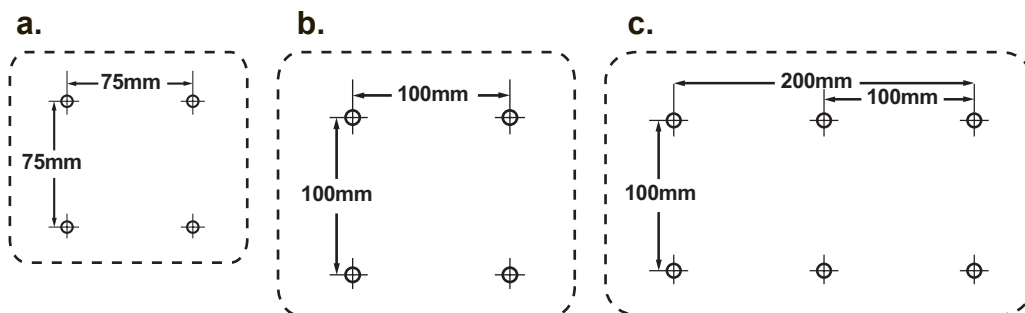

5. Attach the Zero Client Monitor to the wall, following the instructions in the wall-mounting kit.

Attach base:

1.

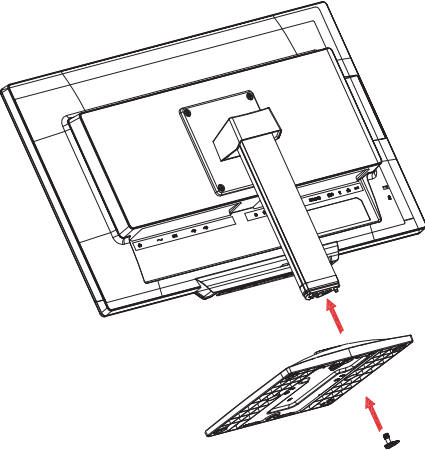

2.

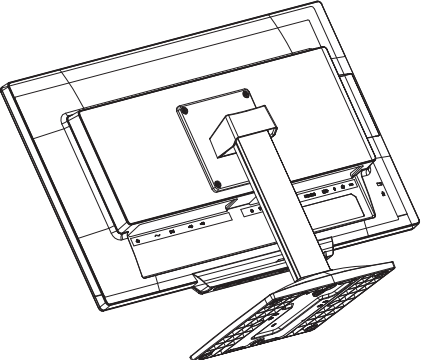

3.

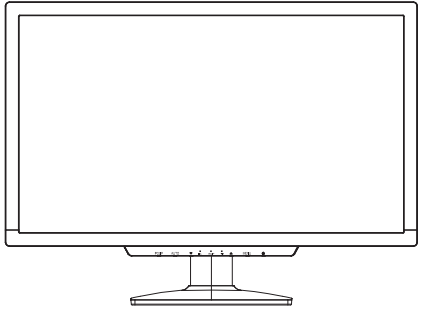

Detach base:

1.

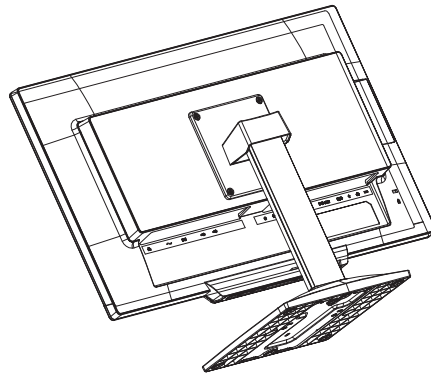

2.

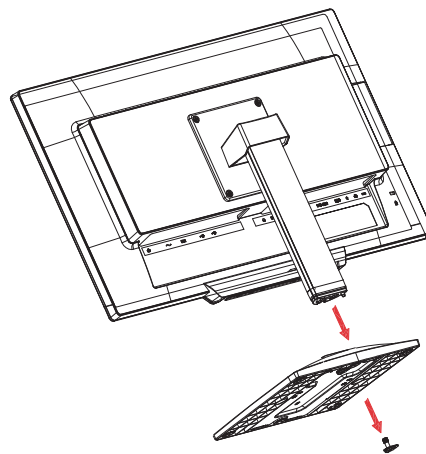

3.

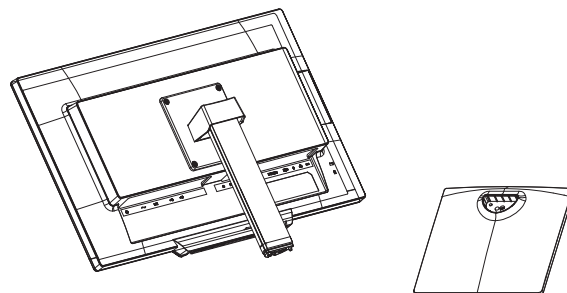

Wall mount kit:

| | |
|---------------------|------------------------|
| Required pitch (mm) | Require mounting bolts |
| 100 x 100 | 4 x M4 (10 mm) |

Using the Zero Client Monitor

Setting the Timing Mode

Setting the timing mode is important for maximizing the quality of the screen image and minimizing eye strain. The **timing mode** consists of the **resolution** (example 1024 x 768) and **refresh rate** (or vertical frequency; example 60 Hz). After setting the timing mode, use the OSD (On-screen Display) controls to adjust the screen image.

For optimal picture quality, please use the recommended timing mode specific to your Zero Client Monitor listed on the "Specification" page.

To set the Timing Mode:

- **Setting the resolution:** Access "Appearance and Personalization" from Control Panel via the Start Menu, and set the resolution.
- **Setting the refresh rate:** See your graphic card's user guide for instructions.





IMPORTANT: Please make sure that your graphics card is set to 60Hz vertical refresh rate as the recommended setting for most Zero Client Monitors. Choosing a non-supported timing mode setting may result in no image being displayed, and a message showing "Out of Range" will appear on screen.

OSD and Power Lock Settings

- **OSD Lock:** Press and hold [1] and the up arrow ▲ for 10 seconds. If any buttons are pressed the message **OSD Locked** will display for 3 seconds.
- **OSD Unlock:** Press and hold [1] and the up arrow ▲ again for 10 seconds.
- **Power Button Lock:** Press and hold [1] and the down arrow ▼ for 10 seconds. If the power button is pressed the message **Power Button Locked** will display for 3 seconds. With or without this setting, after a power failure, your Zero Client Monitor's power will automatically turn ON when power is restored.
- **Power Button Unlock:** Press and hold [1] and the down arrow ▼ again for 10 seconds.

Adjusting the Screen Image

Use the buttons on the front control panel to display and adjust the OSD controls which display on the screen.

| | |
|---|---|
|  | Standby Power On/Off |
| [1] | MENU/EXIT Displays the Main Menu or exits the control screen and saves adjustments. |
| [2] | SOURCE/ENTER Displays the control screen for the highlighted control. Also a shortcut to toggle analog and PCoIP. |
| ▲/▼ | Scrolls through menu options and adjusts the displayed control. Audio Adjust (▼) / Brightness/Contrast (▲) |
|  Power | Power indicator Blue = ON Orange = Power Saving |
|  PCoIP | PCoIP indicator Green = PCoIP activate Orange = Standby Blank = PCoIP OFF |
|  link | Link indicator Blue = When the Client is connected. |
| PCoIP | Activate the PCoIP when the Client is connected. |

* PCoIP: PC over IP is a display protocol that allows complete compression of a desktop displayed through a zero client device over standard IP network.

Do the following to adjust the display setting:

1. To display the Main Menu, press button [1].
NOTE: All OSD menus and adjustment screens disappear automatically after about 15 seconds. This is adjustable through the OSD timeout setting in the setup menu.
2. To select a control to adjust, press ▲ or ▼ to scroll up or down in the Main Menu.
3. After the desired control is selected, press button [2].
4. To save the adjustments and exit the menu, press button [1] until OSD disappear.

The following tips may help you optimize your display:

- Adjust the computer's graphics card to support a recommended timing mode (refer to "Specifications" page for recommended setting specific to your Zero Client Monitor). To find instructions on "changing the refresh rate", please refer to the graphics card's user guide.
- If necessary, make small adjustments using H. POSITION and V. POSITION until the screen image is completely visible. (The black border around the edge of the screen should barely touch the illuminated "active area" of the Zero Client Monitor.)

Main Menu Controls

Adjust the menu items by using the up ▲ and down ▼ buttons.

NOTE: Check the Main Menu items on your LCD OSD and refer to Main Menu Explanation below.

Main Menu Explanation

NOTE: The Main Menu items listed in this section indicates whole Main Menu items of all models. The actual Main Menu details corresponding to your product please refer to your LCD OSD Main Menu items.

A Audio Adjust

adjusts the volume, mutes the sound.

Auto Image Adjust

automatically sizes, centers, and fine tunes the video signal to eliminate waviness and distortion. Press the [2] button to obtain a sharper image.

NOTE: Auto Image Adjust works with most common video cards. If this function does not work on your Zero Client Monitor, then lower the video refresh rate to 60 Hz and set the resolution to its pre-set value.

B Brightness

adjusts background black level of the screen image.

C Color Adjust

provides several color adjustment modes, including preset color temperatures and a User Color mode which allows independent adjustment of red (R), green (G), and blue (B). The factory setting for this product is native.

Contrast

adjusts the difference between the image background (black level) and the foreground (white level).

I Information

displays the timing mode (video signal input) coming from the graphics card in the computer, the LCD model number, the serial number, and the ViewSonic® website URL. See your graphics card's user guide for instructions on changing the resolution and refresh rate (vertical frequency).

NOTE: VESA 1024 x 768 @ 60Hz (example) means that the resolution is 1024 x 768 and the refresh rate is 60 Hertz.

Input Select

toggles between inputs if you would like to switch D-sub and PCoIP.

M Manual Image Adjust

displays the Manual Image Adjust menu. You can manually set a variety of image quality adjustments.

Memory Recall

returns the adjustments back to factory settings if the display is operating in a factory Preset Timing Mode listed in the Specifications of this manual.

Exception: This control does not affect changes made with the Language Select or Power Lock setting.

S Setup Menu

adjusts On-screen Display (OSD) settings.

Manual of Zero Client, PCoIP firmware update and PCoIP Management Console Software:

1. Please visit ViewSonic website at www.viewsonic.com to download the user guide of Zero Client and PCoIP firmware updates.
2. The latest version of “PCoIP Management Console Software” can be downloaded free of charge from the Teradici web site. You will simply need to create an account first and accept the End User License Agreement (EULA), before downloading:
<http://techsupport.teradici.com/ics/support/default.asp?deptID=15164>

Other Information

Specifications

| | | | |
|--------------------------------|------------------------|--|--|
| Processor | | Teradici Tera2321 / Image Performance 50Mpps | |
| Random Access Memory | | 512 MB | |
| LCD | Type | TFT (Thin Film Transistor), Active Matrix 1920 x 1080 LCD, 0.248 mm pixel pitch | |
| | Display Size | Metric: 55 cm Imperial: 21.5" (21.5" viewable) | |
| | Color Filter | RGB vertical stripe | |
| | Glass Surface | Anti-Glare | |
| D-SUB Input Signal | Video Sync | RGB analog (0.7/1.0 Vp-p, 75 ohms) Separate Sync f_h :24-82 kHz, f_v :50-75 Hz | |
| DVI-I Output resolution | Up to 1920x1200 | | |
| Compatibility | PC | Up to 1920 x 1080 Non-interlaced | |
| | Macintosh ¹ | Power Macintosh up to 1920 x 1080 | |
| Resolution² | Recommended | 1920x1080 @ 50, 60 Hz | |
| | Supported | 1680 x 1050 @ 60 Hz 1600 x 1200 @ 60 Hz 1600 x 900 @ 60 Hz 1400 x 1050 @ 60 Hz 1440 x 900 @ 60, 75 Hz 1360 x 768 @ 60 Hz 1280 x 1024 @ 60, 75 Hz 1280 x 960 @ 60, 75 Hz 1280 x 800 @ 60, 75 Hz 1280 x 768 @ 60, 75 Hz 1280 x 720 @ 50, 60 Hz 1152 x 900 @ 66 Hz | 1152 x 870 @ 75 Hz 1152 x 864 @ 75 Hz 1024 x 768 @ 60, 70, 72, 75, Hz 832 x 624 @ 75 Hz 800 x 600 @ 56, 60, 72, 75 Hz 720 x 576 @ 50 Hz 720 x 480 @ 60 Hz 720 x 400 @ 70 Hz 640 x 480 @ 50, 60, 67, 72, 75 Hz 640 x 400 @ 60,70 Hz 640 x 350 @ 70 Hz |
| I/O interfaces | | Power input x 1, Earphone output x 1, Microphone input x 1, Audio input x 1, D-SUB signal input x 1, USB port 2.0 x 4, DVI-I signal output x 1, RJ45 x 1 | |
| Networking | | 1 x 10/100/1000Mb Ethernet | |
| Power | Voltage | DC Power In: DC +19V, 3.42A | |
| | | External Power Adapter: AC 100-240V, 50/60 Hz, 1.5A | |
| Display area | Full Scan | 476.64 mm (H) x 268.11 mm (V) 18.77" (H) x 10.56" (V) | |
| Operating conditions | Temperature | +32°F to +95°F (0°C to +35°C) | |
| | Humidity | 15% to 90% (non-condensing) | |
| | Altitude | To 16,400 feet | |
| Storage conditions | Temperature | -4°F to +140°F (-20°C to +60°C) | |
| | Humidity | 15% to 90% (non-condensing) | |
| | Altitude | To 16,404 feet | |

| | | |
|-------------------|----------|--|
| Dimensions | Physical | 512.4 mm (W) x 376.7 mm (H) x 189.93 mm (D) 20.17" (W) x 14.83" (H) x 7.48" (D) |
| Wall Mount | Distance | 100 x 100 mm |
| Net weight | Physical | 9.92 lbs (4.5 kg) (with Stand) |

¹ Macintosh computers older than G3 require a ViewSonic® Macintosh adapter. To order an adapter, contact ViewSonic.

² Do not set the graphics card in your computer to exceed these timing mode; doing so may result in permanent damage to the Zero Client Monitor.

Cleaning the Zero Client Monitor

- MAKE SURE THE ZERO CLIENT MONITOR IS TURNED OFF.
- NEVER SPRAY OR POUR ANY LIQUID DIRECTLY ONTO THE SCREEN OR CASE.

To clean the screen:

1. Wipe the screen with a clean, soft, lint-free cloth. This removes dust and other particles.
2. If the screen still not clean, apply a small amount of non-ammonia, non-alcohol based glass cleaner onto a clean, soft, lint-free cloth, and wipe the screen.

To clean the case:

1. Use a soft, dry cloth.
2. If the case still not clean, apply a small amount of a non-ammonia, non-alcohol based, mild non-abrasive detergent onto a clean, soft, lint-free cloth, then wipe the surface.

Disclaimer

- ViewSonic® does not recommend the use of any ammonia or alcohol-based cleaners on the Zero Client Monitor screen or case. Some chemical cleaners have been reported to damage the screen and/or case of the Zero Client Monitor.
- ViewSonic will not be liable for damage resulting from use of any ammonia or alcoholbased cleaners.

Troubleshooting

No power

- Make sure power button (or switch) is ON.
- Make sure A/C or DC power cord is securely connected to the Zero Client Monitor.
- Plug another electrical device (like a radio) into the power outlet to verify that the outlet is supplying proper voltage.

Power is ON but no screen image

- Make sure the video cable supplied with the Zero Client Monitor is tightly secured to the video output port on the back of the computer. If the other end of the video cable is not attached permanently to the Zero Client Monitor, tightly secure it to the Zero Client Monitor.
- Adjust brightness and contrast.
- If you are using an Macintosh older than G3, you need a Macintosh adap

Wrong or abnormal colors

- If any colors (red, green, or blue) are missing, check the video cable to make sure it is securely connected. Loose or broken pins in the cable connector could cause an improper connection.
- Connect the Zero Client Monitor to another computer.
- If you have an older graphics card, contact ViewSonic® for a non-DDC adapter.

Control buttons do not work

- Press only one button at a time.

Customer Support

For technical support or product service, see the table below or contact your reseller.
NOTE: You will need the product serial number.

| Country/Region | Website | T = Telephone F = FAX | Email |
|---|-------------------------|---|---|
| Australia New Zealand | www.viewsonic.com.au | AUS= 1800 880 818 NZ= 0800 008 822 | service@au.viewsonic.com |
| Canada | www.viewsonic.com | T (Toll-Free)= 1-866-463-4775 T (Toll)= 1-424-233-2533 F= 1-909-468-3757 | service.ca@viewsonic.com |
| Europe | www.viewsoniceurope.com | www.viewsoniceurope.com/uk/support/call-desk/ | |
| Hong Kong | www.hk.viewsonic.com | T= 852 3102 2900 | service@hk.viewsonic.com |
| India | www.in.viewsonic.com | T= 1800 266 0101 | service@in.viewsonic.com |
| Korea | www.kr.viewsonic.com | T= 080 333 2131 | service@kr.viewsonic.com |
| Latin America (Argentina) | www.viewsonic.com/la/ | T= 0800-4441185 | soporte@viewsonic.com |
| Latin America (Chile) | www.viewsonic.com/la/ | T= 1230-020-7975 | soporte@viewsonic.com |
| Latin America (Columbia) | www.viewsonic.com/la/ | T= 01800-9-157235 | soporte@viewsonic.com |
| Latin America (Mexico) | www.viewsonic.com/la/ | T= 001-8882328722 | soporte@viewsonic.com |
| Renta y Datos, 29 SUR 721, COL. LA PAZ, 72160 PUEBLA, PUE. Tel: 01.222.891.55.77 CON 10 LINEAS Electroser, Av Reforma No. 403Gx39 y 41, 97000 Mérida, Yucatán. Tel: 01.999.925.19.16 Other places please refer to http://www.viewsonic.com/la/soporte/index.htm#Mexico | | | |
| Latin America (Peru) | www.viewsonic.com/la/ | T= 0800-54565 | soporte@viewsonic.com |
| Macau | www.hk.viewsonic.com | T= 853 2870 0303 | service@hk.viewsonic.com |
| Middle East | ap.viewsonic.com/me/ | Contact your reseller | service@ap.viewsonic.com |
| Puerto Rico & Virgin Islands | www.viewsonic.com | T= 1-800-688-6688 (English) T= 1-866-379-1304 (Spanish) F= 1-909-468-3757 | service.us@viewsonic.com soporte@viewsonic.com |
| Singapore/ Malaysia/Thailand | www.ap.viewsonic.com | T= 65 6461 6044 | service@sg.viewsonic.com |
| South Africa | ap.viewsonic.com/za/ | Contact your reseller | service@ap.viewsonic.com |
| United States | www.viewsonic.com | T (Toll-Free)= 1-800-688-6688 T (Toll)= 1-424-233-2530 F= 1-909-468-3757 | service.us@viewsonic.com |

Limited Warranty

ViewSonic® Zero Client

What the warranty covers:

ViewSonic warrants its products to be free from defects in material and workmanship during the warranty period. If a product proves to be defective in material or workmanship during the warranty period, ViewSonic will, at its sole option, repair or replace the product with a similar product. Replacement Product or parts may include remanufactured or refurbished parts or components. The replacement unit will be covered by the balance of the time remaining on the customer's original limited warranty. ViewSonic provides no warranty for the third-party software included with the product or installed by the customer.

How long the warranty is effective:

ViewSonic Zero Client products are warranted for (3) years from the first consumer purchase for parts and labor.

User is responsible for the back up of any data before returning the unit for service. ViewSonic is not responsible for any data lost.

Who the warranty protects:

This warranty is valid only for the first consumer purchaser.

What the warranty does not cover:

1. Any product on which the serial number has been defaced, modified or removed.
2. Damage, deterioration or malfunction resulting from:
 - a. Accident, misuse, neglect, fire, water, lightning, or other acts of nature, unauthorized product modification, or failure to follow instructions supplied with the product.
 - b. Any damage of the product due to shipment.
 - c. Removal or installation of the product.
 - d. Causes external to the product, such as electrical power fluctuations or failure.
 - e. Use of supplies or parts not meeting ViewSonic's specifications.
 - f. Normal wear and tear.
 - g. Any other cause which does not relate to a product defect.
3. Any product exhibiting a condition commonly known as "image burn-in" which results when a static image is displayed on the product for an extended period of time.
4. Removal, installation, one way transportation, insurance, and set-up service charges.

How to get service:

1. For information about receiving service under warranty, contact ViewSonic Customer Support (Please refer to Customer Support page). You will need to provide your product's serial number.
2. To obtain warranty service, you will be required to provide (a) the original dated sales slip, (b) your name, (c) your address, (d) a description of the problem, and (e) the serial number of the product.
3. Take or ship the product freight prepaid in the original container to an authorized ViewSonic service center or ViewSonic.
4. For additional information or the name of the nearest ViewSonic service center, contact ViewSonic.

Limitation of implied warranties:

There are no warranties, express or implied, which extend beyond the description contained herein including the implied warranty of merchantability and fitness for a particular purpose.

Exclusion of damages:

ViewSonic's liability is limited to the cost of repair or replacement of the product. ViewSonic shall not be liable for:

1. Damage to other property caused by any defects in the product, damages based upon inconvenience, loss of use of the product, loss of time, loss of profits, loss of business opportunity, loss of goodwill, interference with business relationships, or other commercial loss, even if advised of the possibility of such damages.
2. Any other damages, whether incidental, consequential or otherwise.
3. Any claim against the customer by any other party.
4. Repair or attempted repair by anyone not authorized by ViewSonic.

Effect of state law:

This warranty gives you specific legal rights, and you may also have other rights which vary from state to state. Some states do not allow limitations on implied warranties and/or do not allow the exclusion of incidental or consequential damages, so the above limitations and exclusions may not apply to you.

Sales outside the U.S.A. and Canada:

For warranty information and service on ViewSonic products sold outside of the U.S.A. and Canada, contact ViewSonic or your local ViewSonic dealer.

The warranty period for this product in mainland China (Hong Kong, Macao and Taiwan Excluded) is subject to the terms and conditions of the Maintenance Guarantee Card.

For users in Europe and Russia, full details of warranty provided can be found in www.viewsoniceurope.com under Support/Warranty Information.



ViewSonic®